

To avoid dangers, do not overreach or overload a suspended working platform.

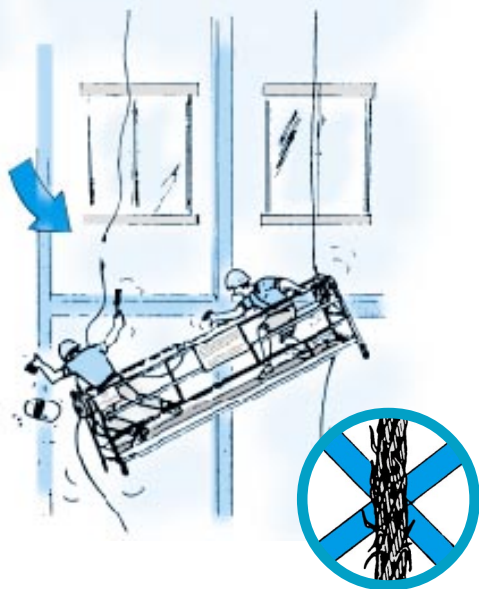

It is very dangerous to use rusty, kinky or damaged ropes. They should be replaced immediately.

Further information can be obtained from the Occupational Safety and Health Branch of the Labour Department. If necessary, please contact us.



Enquiry

Advisory Unit, Occupational Safety and Health Branch, Labour Department

☎ Telephone : 2559 2297

📠 Fax : 2915 1410

💻 E-mail : enquiry@labour.gov.hk

Information on the services offered by the Occupational Safety and Health Council can be obtained through hotline 2739 9000.

Safety Hints on Operation of Suspended Working Platforms

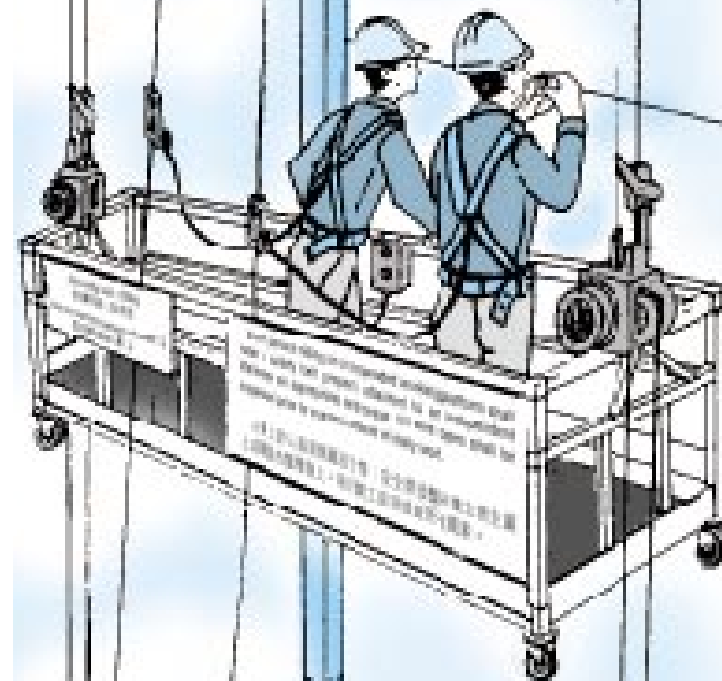

Occupational Safety and Health Branch
Labour Department



Occupational Safety & Health Council

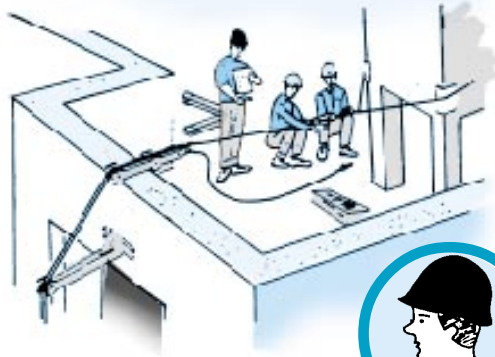

The erection and dismantling of a suspended working platform and the alteration of any structure from its original design should only be carried out under the supervision of a competent person.



A suspended working platform should be load tested and examined by a registered professional engineer after erection or repositioning. Moreover, the suspended working platform should be inspected by a competent person at least once a week and all suspension ropes and safety ropes should be inspected prior to commencement of daily work.

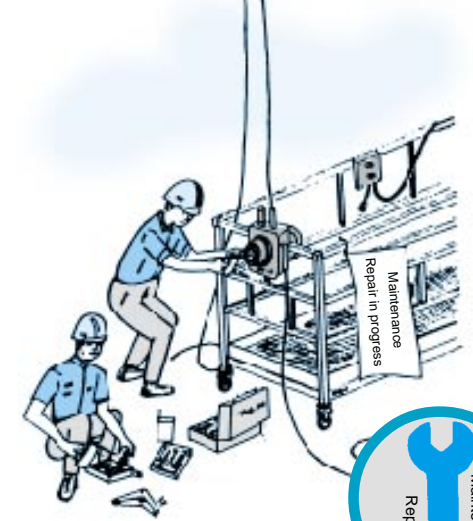

All the equipment of a suspended working platform should be properly maintained and the record thereof should also be kept properly.

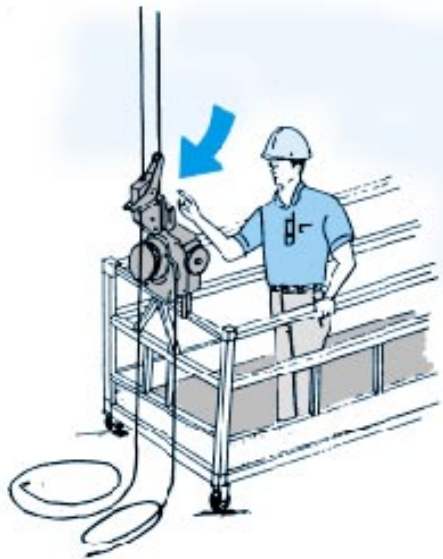

A suspended working platform should be installed with a safety rope with an automatic safety device mounted on it. No person shall tamper or interfere with or render inoperative such safety rope and automatic safety device.



Every person working on a suspended working platform should be at least 18 years old and has undergone training to operate the suspended working platform and obtained a certificate in respect of such training. They should wear safety belts and attach them to independent lifelines.

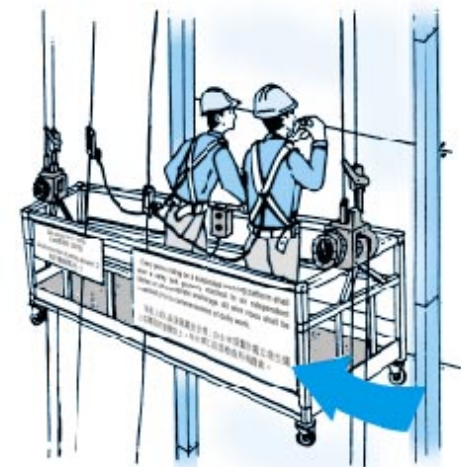

A notice specifying the safe working load, number of persons allowed on a suspended working platform and the inspection of ropes should be posted on the suspended working platform. The notice should also remind workers to use safety belts and lifelines.